

### Feature

This device is Pb-Free, Halogen Free/BFR Free and RoHS compliant.

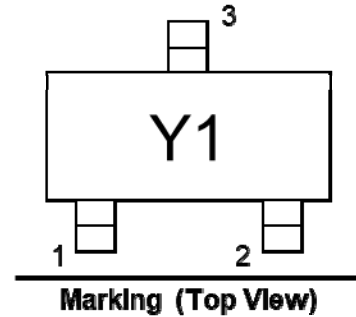
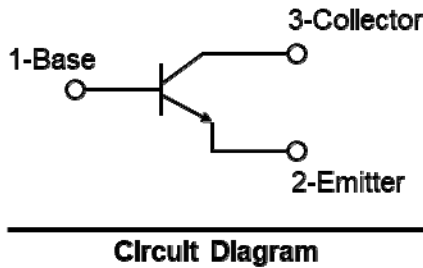

### Mechanical Characteristics

- Lead finish:100% matte Sn(Tin)
- Mounting position: Any
- Qualified max reflow temperature:260°C
- Device meets MSL 1 requirements
- Pure tin plating: 7 ~ 17 um
- Pin flatness : ≤3mil

### Structure

NPN epitaxial planar silicon transistor (Resistor built-in type)

### Absolute maximum rating@25°C

Parameter	Symbol	Value	Units
Collector-Base Voltage	$V_{CBO}$	40	V
Collector-Emitter Voltage	$V_{CEO}$	25	V
Emitter-Base Voltage	$V_{EBO}$	5	V
Collector Current	$I_C$	1.5	A
Collector Power Dissipation	$P_C$	300	mW
Thermal Resistance From Junction To Ambient	$R_{\theta JA}$	417	°C/W
Junction Temperature	$T_j$	150	°C
Storage Temperature	$T_{stg}$	-55~+150	°C

Electrical characteristics per line@25°C ( unless otherwise specified)

Parameter	Symbol	Conditions	Min.	Typ.	Max.	Units
DC Current Gain	$h_{FE}$	$I_C=50mA, V_{CE}=1.0V$	200		350	-
Collector-Emitter Saturation Voltage	$V_{CE(sat)}$	$I_C=500mA, I_B=50mA$	-		0.5	V
Base-Emitter Saturation Voltage	$V_{BE(sat)}$	$I_C=500mA, I_B=50mA$			1.2	V
Collector-Emitter Breakdown Voltage	$V_{(BR)CEO}$	$I_C=2.0mA, I_B=0$	25			V
Collector-Base Breakdown Voltage	$V_{(BR)CBO}$	$I_C=10\mu A, I_E=0$	40			V
Emitter -Base Breakdown Voltage	$V_{(BR)EBO}$	$I_E=100\mu A, I_C=0$	6.0			V
Base Cutoff Current	$I_{BL}$	$V_{CB}=35V$			50	nA
Collector Current	$I_C$			1.5		A

Typical Characteristics

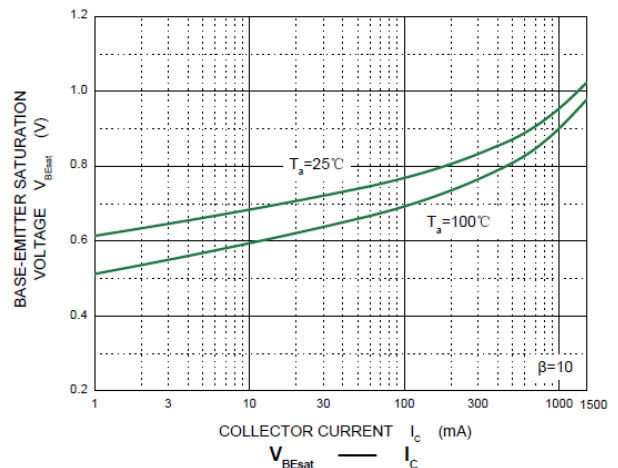
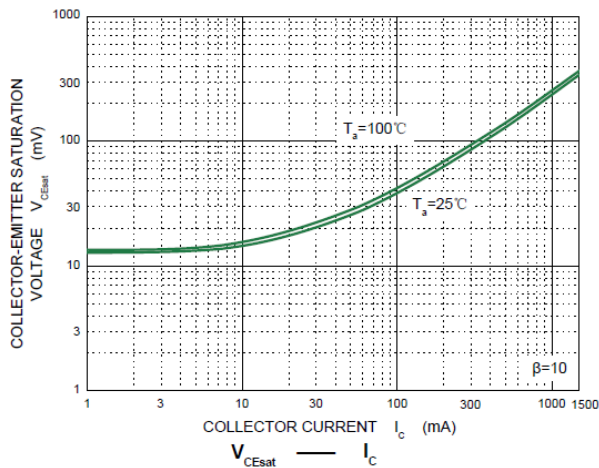
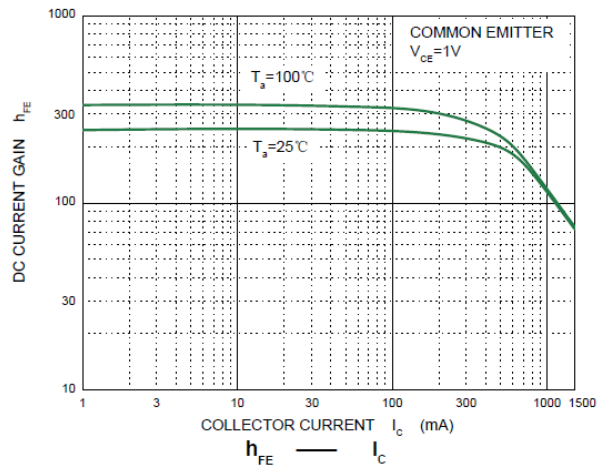
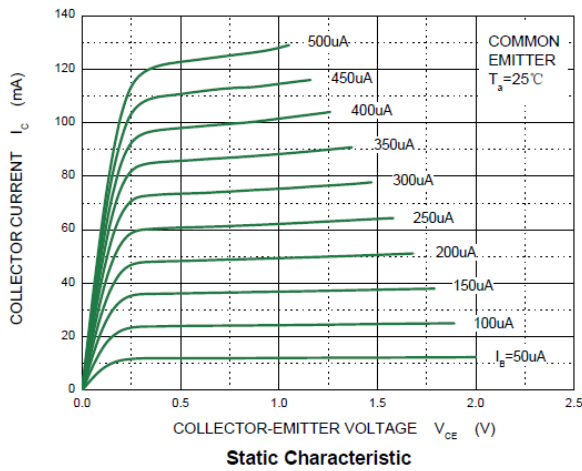

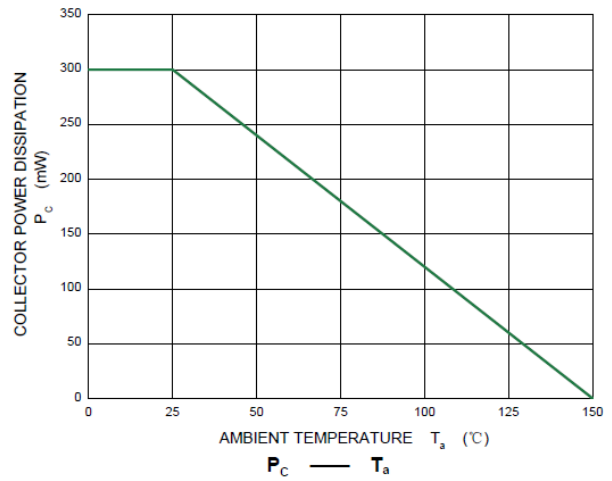
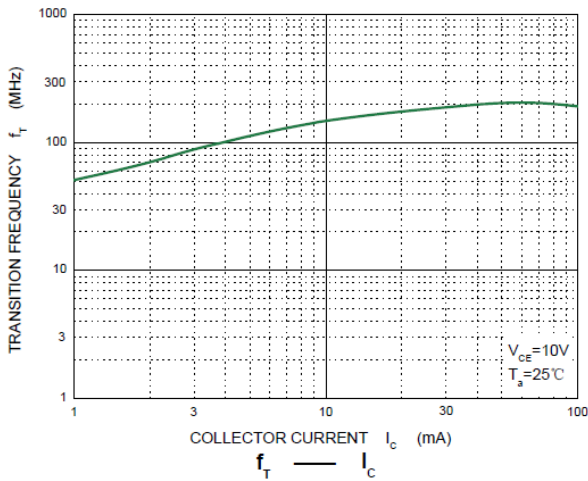
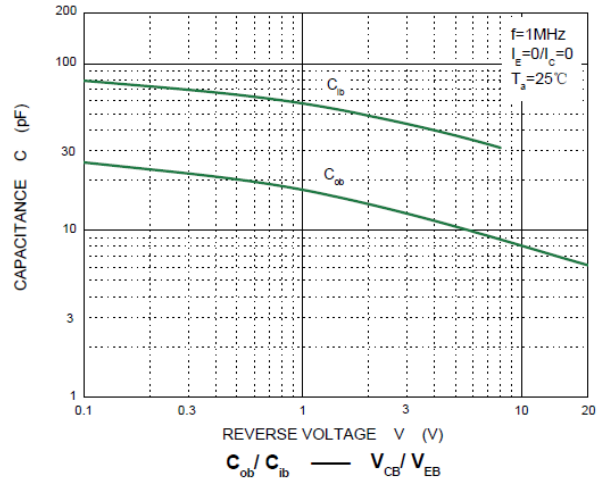
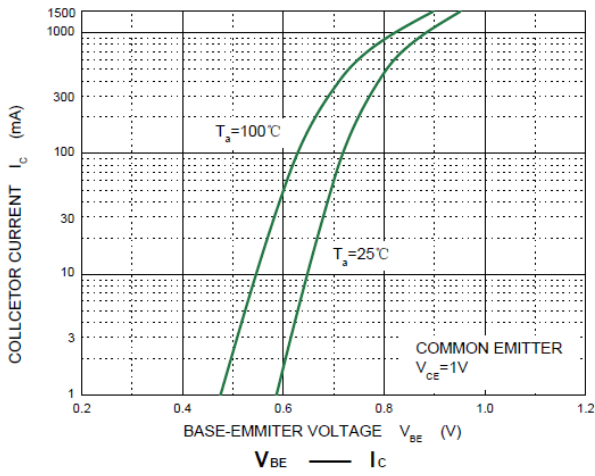

Solder Reflow Recommendation

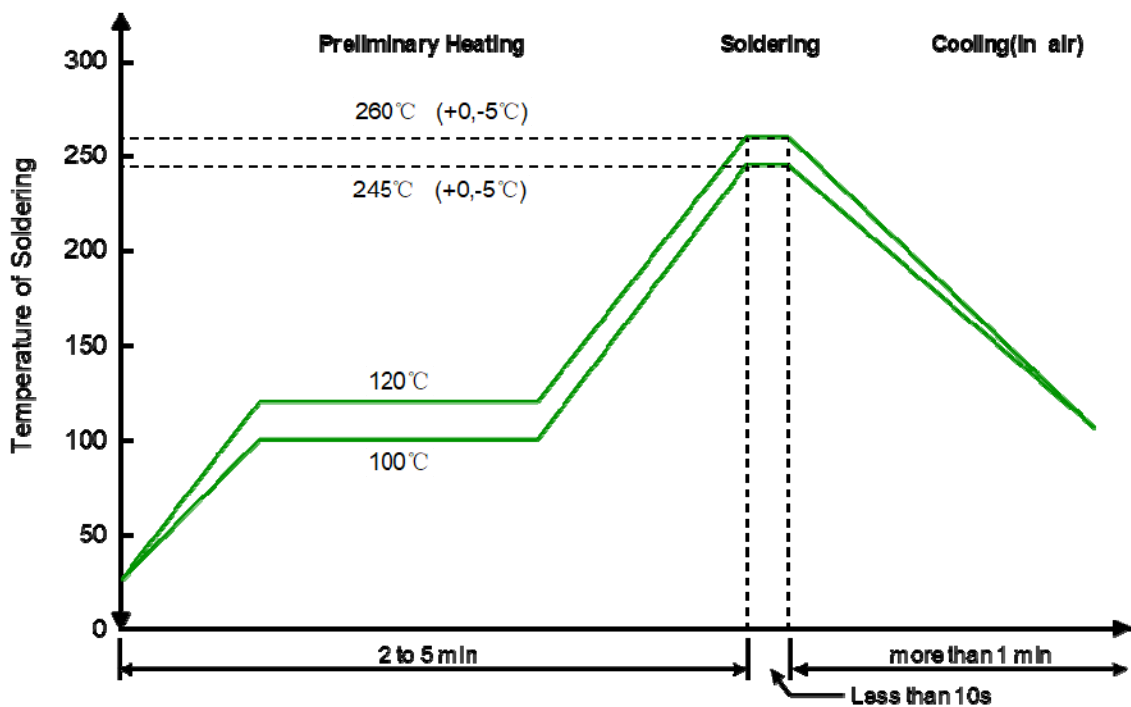

Remark: Pb free for 260°C. Pb for 245°C.

Product dimension (SOT-23)

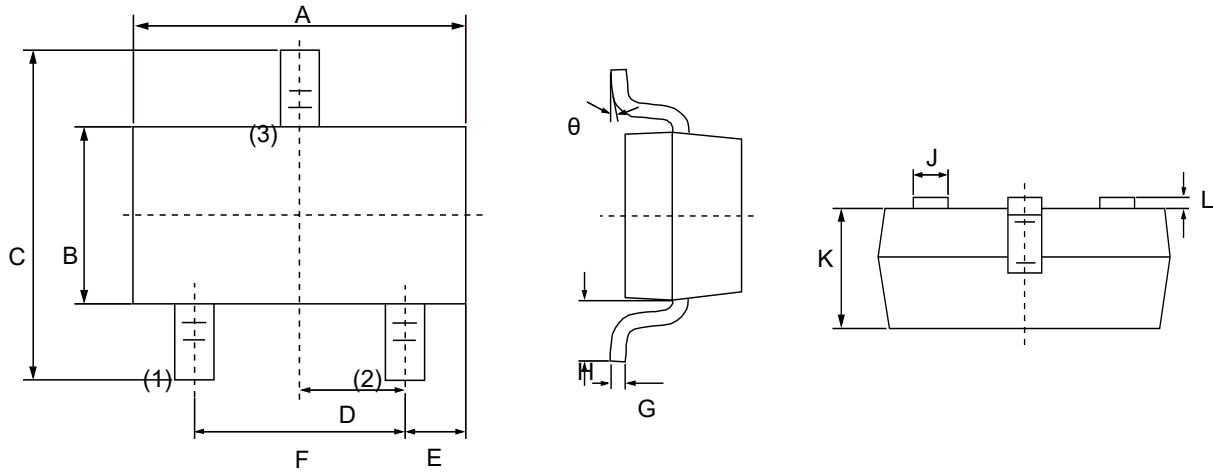

Dim	Millimeters		Inches	
	MIN	MAX	MIN	MAX
A	2.80	3.00	0.1102	0.1197
B	1.20	1.40	0.0472	0.0551
C	2.10	2.50	0.0830	0.0984
D	0.89	1.02	0.0350	0.0401
E	0.45	0.60	0.0177	0.0236
F	1.78	2.04	0.0701	0.0807
G	0.085	0.177	0.0034	0.0070
H	0.45	0.60	0.0180	0.0236
J	0.37	0.50	0.0150	0.0200
K	0.89	1.11	0.0350	0.0440
L	0.013	0.100	0.0005	0.0040
$\theta$	0°	10°	0°	10°

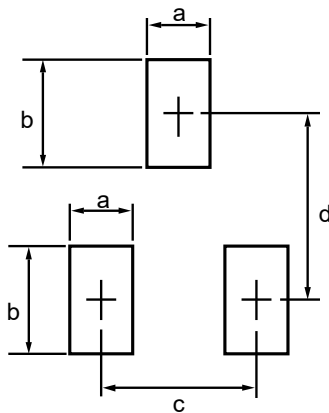

Dim	Millimeters	
	MIN	MAX
a	--	0.7
b	--	1.2
c	--	2.04
d	--	2.2

Ordering information

Device	Package	Shipping
PT23T8050	SOT-23	3000 / Tape & Reel

**IMPORTANT NOTICE**

 and **Prisemi**<sup>®</sup> are registered trademarks of **Prisemi Electronics Co., Ltd** (Prisemi) ,Prisemi reserves the right to make changes without further notice to any products herein. Prisemi makes no warranty, representation or guarantee regarding the suitability of its products for any particular purpose, nor does Prisemi assume any liability arising out of the application or use of any product or circuit, and specifically disclaims any and all liability, including without limitation special, consequential or incidental damages. "Typical" parameters which may be provided in Prisemi data sheets and/or specifications can and do vary in different applications and actual performance may vary over time. All operating parameters, including "Typicals" must be validated for each customer application by customer's technical experts. Prisemi does not convey any license under its patent rights nor the rights of others. The products listed in this document are designed to be used with ordinary electronic equipment or devices, Should you intend to use these products with equipment or devices which require an extremely high level of reliability and the malfunction of with would directly endanger human life (such as medical instruments, aerospace machinery, nuclear-reactor controllers, fuel controllers and other safety devices), please be sure to consult with our sales representative in advance.

Website: <http://www.prisemi.com>

For additional information, please contact your local Sales Representative.

©Copyright 2009, Prisemi Electronics

 **Prisemi**<sup>®</sup> is a registered trademark of Prisemi Electronics.

All rights are reserved.