

650V Enhancement-mode GaN Transistor

Description

650V Normally-OFF GaN			
$V_{DS}(V)$	$R_{DS(on)}(m\Omega)$	$I_{DS}(A)$	$Q_G(nC)$
650	160	16	7.9



TO-220F (Top View)

Feature

- Normally-off device combines high voltage GaN HEMT and low voltage silicon MOSFET
- Normally off power switch
- Low reverse-recovery charge
- High switching frequency
- Low gate charge, low output charge
- Qualified for industrial applications according to JEDEC Standards
- Package: TO-220F

Applications

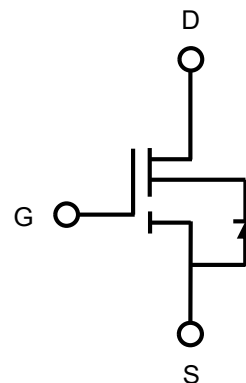
- Fast charger
- Renewable energy
- Telecom and data-com
- Servo motors
- Industrial
- Automotive

Circuit Diagram

Absolute maximum rating@25°C

Rating	Symbol	Value	Units
Drain-Source Voltage	V_{DS}	650	V
Drain-Source Voltage-transient ¹⁾	$V_{DS(transient)}$	800	V
Gate-Source Voltage	V_{GS}	-20 to +20	V
Drain Current-Continuous ²⁾	$T_C = 25^\circ C$	16	A
	$T_C = 125^\circ C$	7.0	A
Pulse Drain Current (pulse width: 100 μ s)	I_{DM}	27	A
Maximum Power Dissipation	P_D	78	W
Junction and Storage Temperature Range	T_J, T_{STG}	-55~+150	°C

Notes:

1. In off-state, spike duty cycle $D < 0.01$, spike duration $< 1\mu s$
2. For increased stability at high current operation.

Thermal characteristics

Parameter	Symbol	Min.	Typ.	Max.	Units
Thermal Resistance, Junction - Case	$R_{\theta JC}$	-	1.6	-	°C/W

Electrical characteristics per line@25°C (unless otherwise specified)

Parameter	Symbol	Conditions	Min.	Typ.	Max.	Units
Drain-Source Breakdown Voltage	BV_{DSS}	$V_{GS} = 0V$	650	-	-	V
Total Drain Leakage Current	I_{DSS}	$V_{DS} = 650V, V_{GS} = 0V, T_J = 25^\circ C$	-	-	10	μA
		$V_{DS} = 650V, V_{GS} = 0V, T_J = 150^\circ C$	-	-	100	
Gate Threshold Voltage	$V_{GS(th)}$	$V_{GS} = V_{DS}, I_D = 1mA$	3.3	4	4.8	V
Gate Threshold Voltage Temperature Coefficient	$\Delta V_{GS(th)}/T_J$		-	-7	-	mV/°C
Gate-Source Leakage Current	I_{GSS}	$V_{GS} = \pm 20V$	-	-	± 100	nA
Static Drain-Source On-Resistance	$R_{DS(on)}$	$V_{GS} = 10V, I_D = 1A, T_J = 25^\circ C$	-	160	220	m Ω
		$V_{GS} = 10V, I_D = 1A, T_J = 150^\circ C$	-	340	-	
Input Capacitance	C_{iss}	$V_{DS} = 400V, V_{GS} = 0V, f = 1MHz$	-	293	-	μF
Output Capacitance	C_{oss}		-	17	-	
Reverse Transfer Capacitance	C_{rss}		-	3.74	-	
Output Charge	Q_{oss}	$V_{GS} = 0V, V_{DS} = 0V \text{ to } 400V, f = 1MHz$	-	22.2	-	nC
Total Gate Charge	Q_g	$V_{GS} = 0 \text{ to } 10V, V_{DS} = 400V, I_D = 1A$	-	7.9	-	nC
Gate-Source Charge	Q_{gs}		-	2.31	-	
Gate-Drain Charge	Q_{gd}		-	1.65	-	
Turn-on Delay Time	$t_{d(on)}$	$V_{DS} = 400V, V_{GS} = 0V \text{ to } 10V, I_D = 2.1A, R_{G-on(ext)} = 6.8\Omega, R_{G-off(ext)} = 2.2\Omega, L = 250\mu H$	-	3.2	-	ns
Turn-on Rise Time	t_r		-	5.5	-	
Turn-Off Delay Time	$t_{d(off)}$		-	7.4	-	
Turn-Off Fall Time	t_f		-	27	-	
Reverse Device Characteristics						
Diode Forward Voltage	V_{SD}	$V_{GS} = 0V, I_{SD} = 10A$	-	2.5	-	V
Reverse Recovery Time	t_{rr}	$I_F = 10A, V_{DD} = 400V, di_F/dt = 165A/\mu s$	-	14	-	ns
Reverse Recovery Charge	Q_{rr}		-	6.5	-	nC

Typical Characteristics

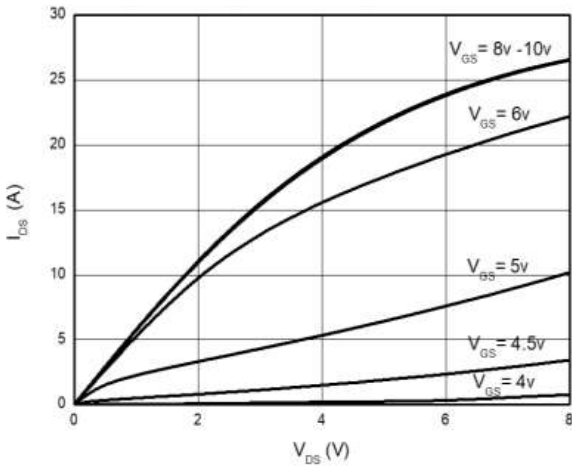

Figure 1. Typical Output Characteristics $T_j=25^\circ\text{C}$

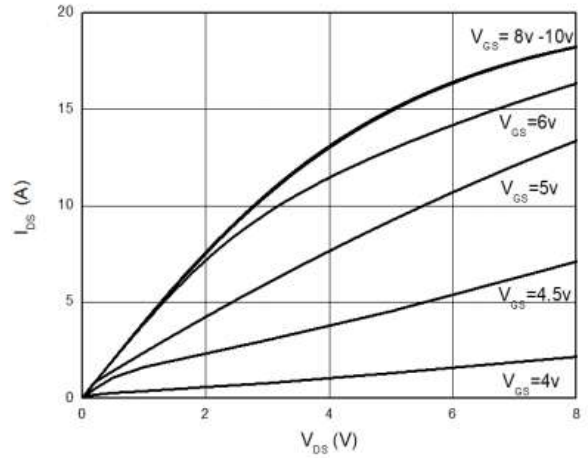

Figure 2. Typical Output Characteristics $T_j=125^\circ\text{C}$

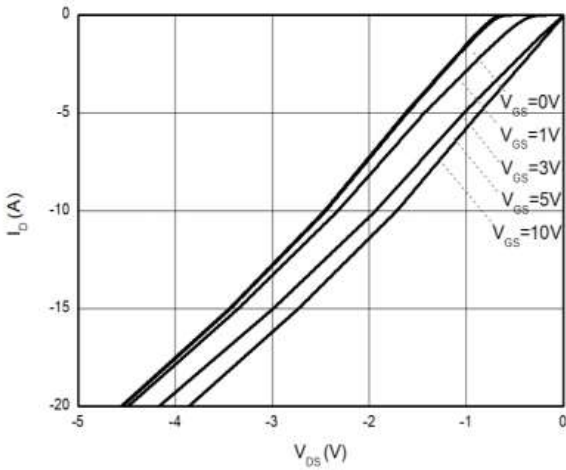

Figure 3. Channel Reverse Characteristics $T_j=25^\circ\text{C}$

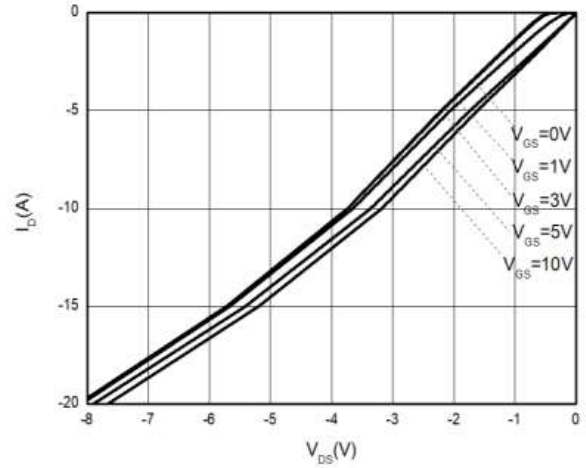

Figure 4. Channel Reverse Characteristics $T_j=125^\circ\text{C}$

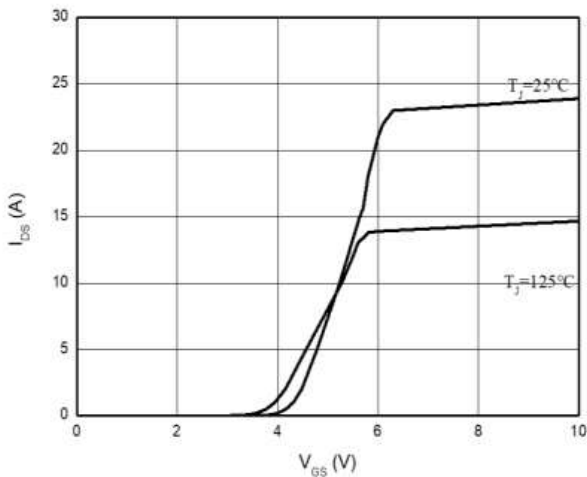

Figure 5. Typical Transfer Characteristics ($V_{ds}=5V$)

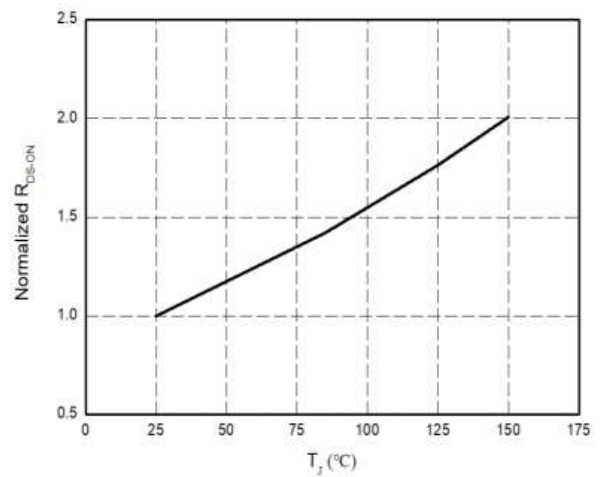

Figure 6. Normalized On-resistance

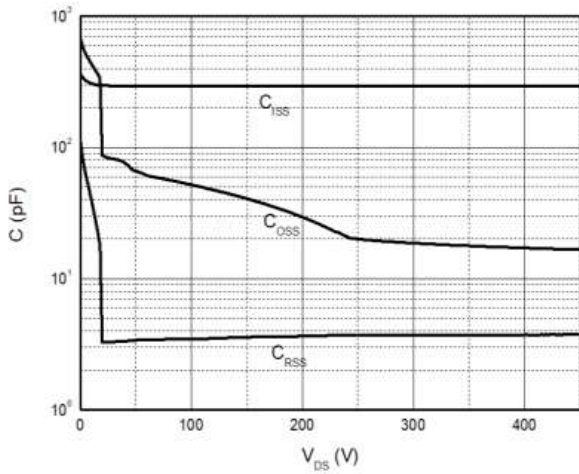

Figure 7. Typical Capacitance (f=1MHz)

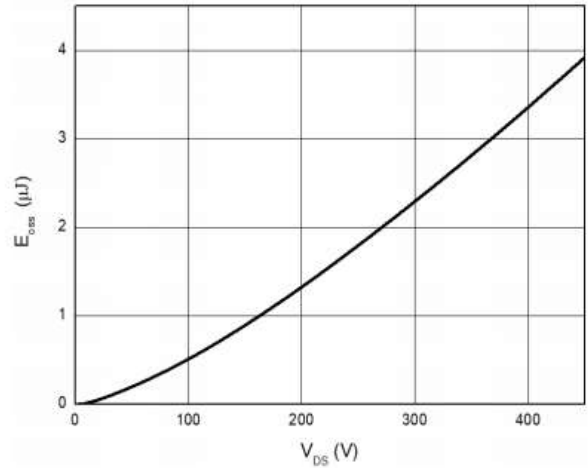

Figure 8. Typical C_{OSS} Stored Energy

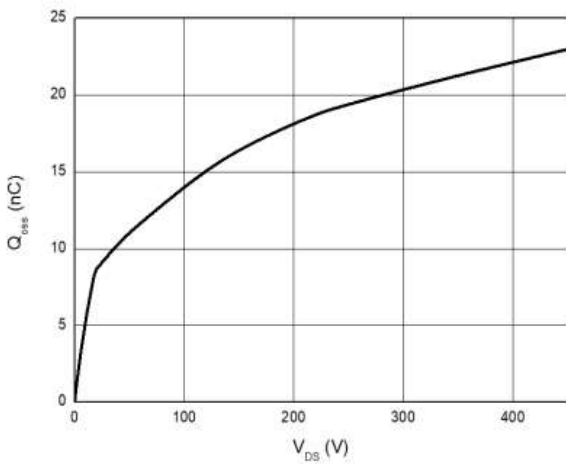

Figure 9. Typical Q_{OSS}

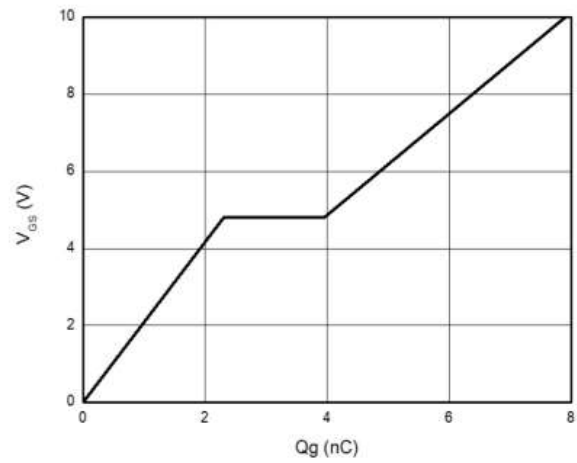

Figure 10. Typical Gate Charge ($V_{DS}=400V$, $I_D=1A$)

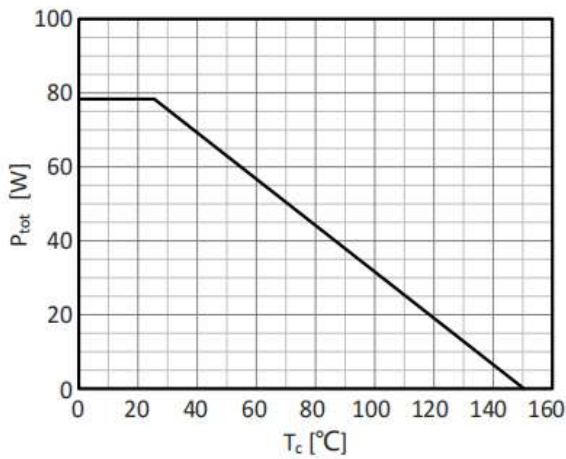

Figure 11. Power Dissipation

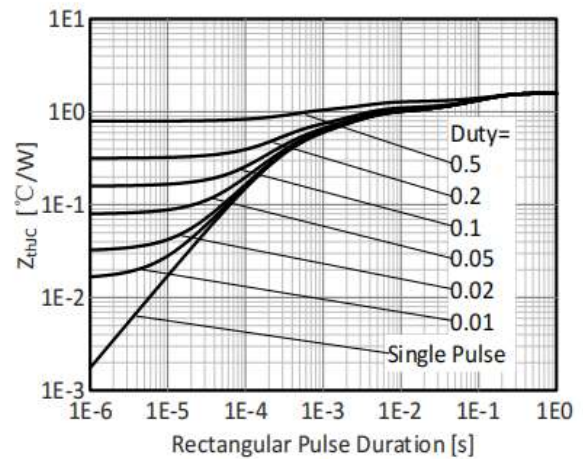

Figure 12. Transient Thermal Resistance

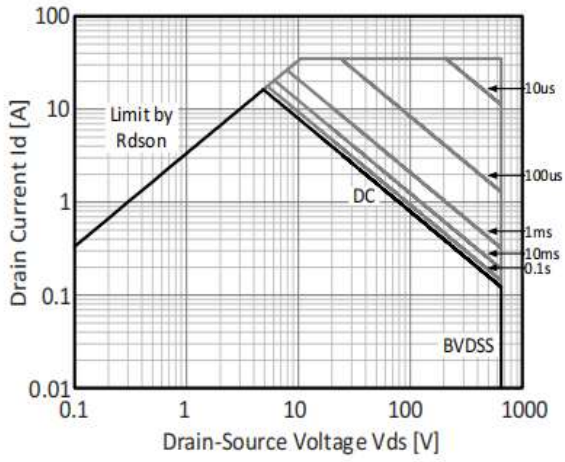

Figure 13. Safe Operating Area $T_c=25^\circ\text{C}$

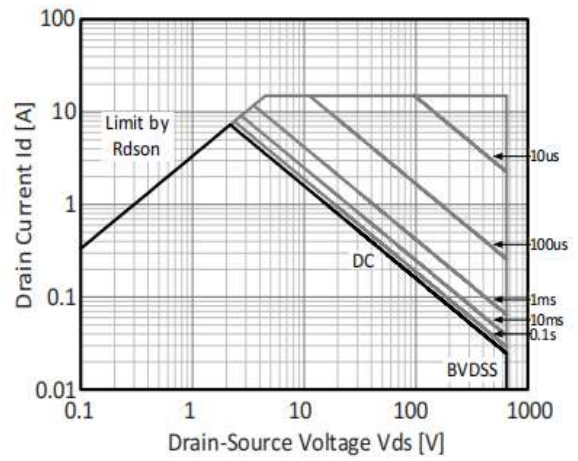
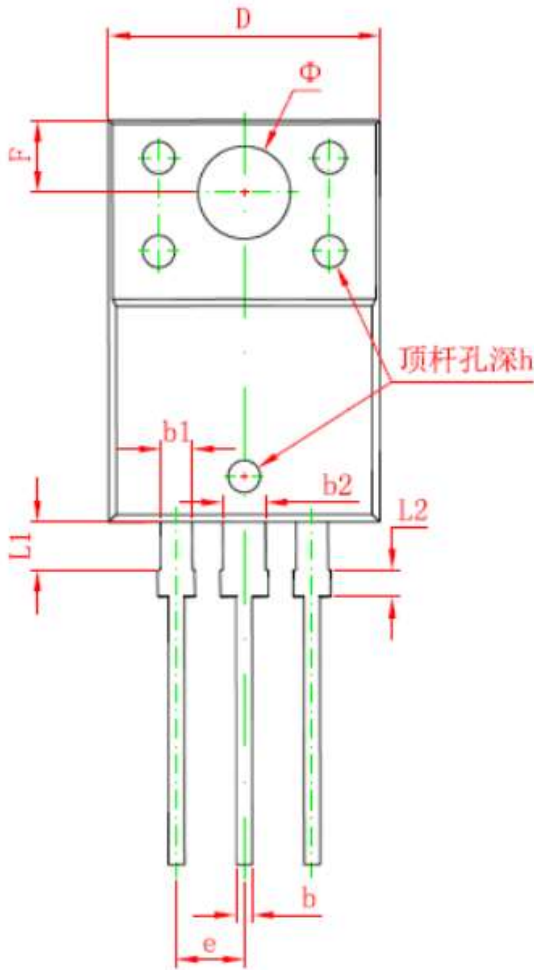

Figure 14. Safe Operating Area $T_c=125^\circ\text{C}$

Product Dimension (TO-220F)

Top view



Side view

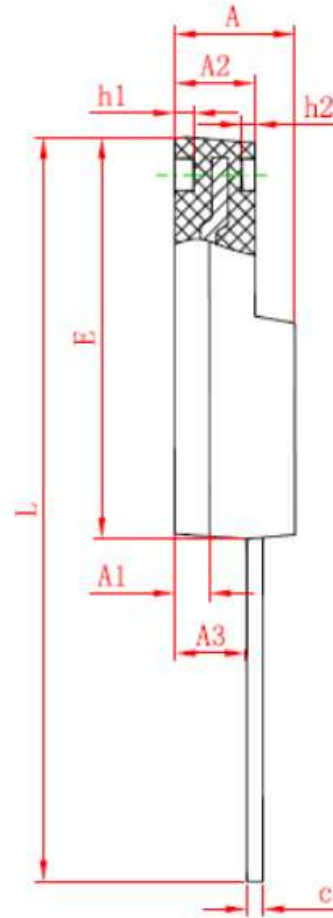

Dim	Millimeters		Inches		Dim	Millimeters		Inches	
	Min	Max	Min	Max		Min	Max	Min	Max
A	4.300	4.700	0.169	0.185	e	2.540 TYP.		0.100 TYP.	
A1	1.300 REF.		1.300 REF.		F	2.700REF.		0.106 REF.	
A2	2.800	3.200	0.110	0.126	Φ	3.500 REF.		0.138 REF.	
A3	2.500	2.900	0.098	0.114	h	0.000	0.300	0.000	0.012
b	0.500	0.750	0.020	0.030	h1	0.800 REF.		0.031 REF.	
b1	1.100	1.350	0.043	0.053	h2	0.500 REF.		0.020 REF.	
b2	1.500	1.750	0.059	0.069	L	28.000	28.400	1.102	1.118
c	0.500	0.750	0.020	0.030	L1	1.700	1.900	0.067	0.075
D	9.960	10.360	0.392	0.408	L2	0.900	1.100	0.035	0.043
E	14.800	15.200	0.583	0.598					

IMPORTANT NOTICE

 and **Prisemi**[®] are registered trademarks of **Prisemi Electronics Co., Ltd** (Prisemi), Prisemi reserves the right to make changes without further notice to any products herein. Prisemi makes no warranty, representation or guarantee regarding the suitability of its products for any particular purpose, nor does Prisemi assume any liability arising out of the application or use of any product or circuit, and specifically disclaims any and all liability, including without limitation special, consequential or incidental damages. "Typical" parameters which may be provided in Prisemi data sheets and/or specifications can and do vary in different applications and actual performance may vary over time. All operating parameters, including "Typicals" must be validated for each customer application by customer's technical experts. Prisemi does not convey any license under its patent rights nor the rights of others. The products listed in this document are designed to be used with ordinary electronic equipment or devices, Should you intend to use these products with equipment or devices which require an extremely high level of reliability and the malfunction of which would directly endanger human life (such as medical instruments, aerospace machinery, nuclear-reactor controllers, fuel controllers and other safety devices), please be sure to consult with our sales representative in advance.

Website: <http://www.prisemi.com>

For additional information, please contact your local Sales Representative.

©Copyright 2009, Prisemi Electronics

 **Prisemi**[®] is a registered trademark of Prisemi Electronics.

All rights are reserved.