

Description

The enhancement mode MOS is extremely high density cell and low on-resistance.

MOSFET Product Summary		
$V_{DS}(V)$	$R_{DS(on)}(m\Omega)$	$I_D(A)$
-20	110 @ $V_{GS}=-4.5V$	-3

Internal structure

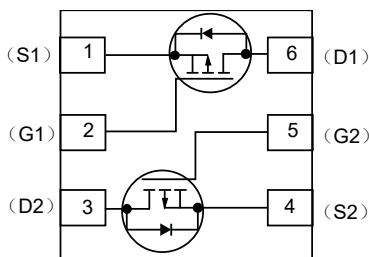

Bottom View

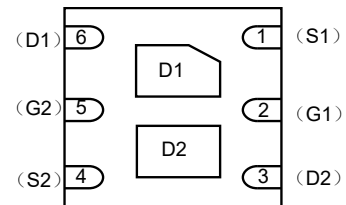

Absolute maximum rating@25°C

Rating	Symbol	Value	Units
Drain-Source Voltage	V_{DS}	-20	V
Gate-Source Voltage	V_{GS}	± 12	V
Drain Current- Continuous	I_D	-3	A
Drain Current- Pulsed	I_{DM}	-10	A
Total Power Dissipation	P_D	1	W
Operating and Storage Junction Temperature Range	T_J, T_{STG}	-55 to +150	°C

Thermal Characteristics

Parameter	Symbol	Max.	Units
Thermal Resistance, Junction to Ambient	$R_{\theta JA}$	125	°C/W

Electrical characteristics per line@25°C (unless otherwise specified)

Parameter	Symbol	Conditions	Min.	Typ.	Max.	Units
Drain-Source Breakdown Voltage	BV_{DSS}	$I_D = -250\mu A, V_{GS} = 0V$	-20	-	-	V
Zero Gate Voltage Drain Current	I_{DSS}	$V_{DS} = -20V, V_{GS} = 0V$	-	-	-1.0	μA
Gate-to-Source Forward Leakage	I_{GSS}	$V_{GS} = \pm 12V$	-	-	± 100	nA
Gate Threshold Voltage	$V_{GS(th)}$	$V_{DS} = V_{GS}, I_D = -250\mu A$	-0.4	-0.7	-1.0	V
Static Drain-Source On-Resistance	$R_{DS(on)}$	$V_{GS} = -4.5V, I_D = -3A$	-	64	110	m Ω
		$V_{GS} = -2.5V, I_D = -2A,$	-	89	140	m Ω
Forward Trans conductance	g_{FS}	$V_{DS} = -5V, I_D = -2.8A$	-	9.5	-	S
Total Gate Charge	Qg	$I_D = -3A, V_{DS} = -10V,$ $V_{GS} = -2.5V$	-	3.3	12	nC
Gate-to-Source Charge	Qgs		-	0.7		
Gate-to-Drain(Miller) Charge	Qgd		-	1.3		
Input Capacitance	C_{ISS}	$V_{GS} = 0V, V_{DS} = -10V,$ $f = 1MHz$	-	405		pF
Output Capacitance	C_{DSS}		-	75		pF
Reverse Transfer Capacitance	C_{RSS}		-	55		pF
Turn-On Delay Time	$t_{d(on)}$	$V_{DD} = -10V, I_D = -1A,$ $V_{GS} = -4.5V, R_{GEN} = 10\Omega,$	-	11		ns
Rise Time	t_r		-	35		
Turn-Off Delay Time	$t_{d(off)}$		-	30		
Fall Time	t_f		-	10		
Diode Forward Voltage	V_{SD}	$V_{GS} = 0V, I_S = -1.3A$			-1.2	V
Diode Forward Current	I_S				-1.3	A

Typical Characteristics

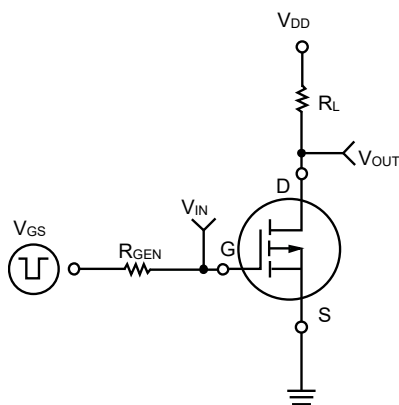

Figure 1. Switching Test Circuit

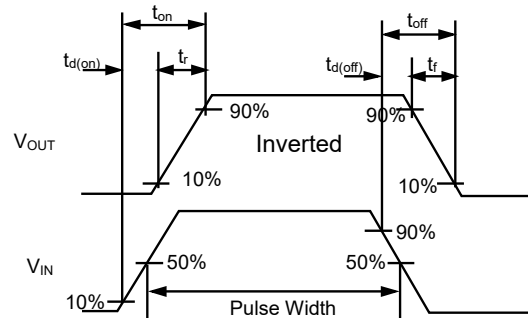
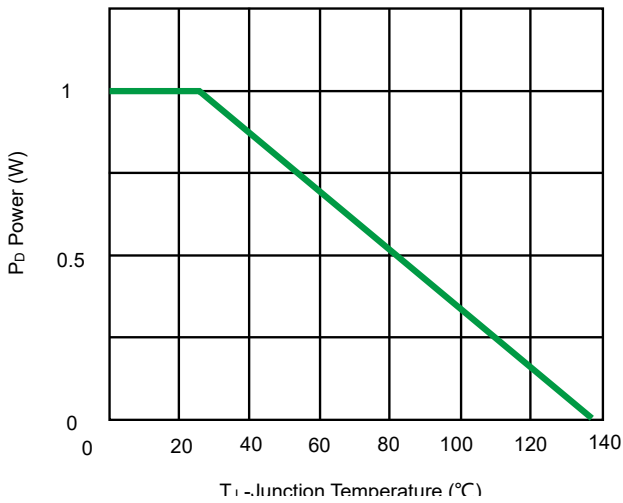
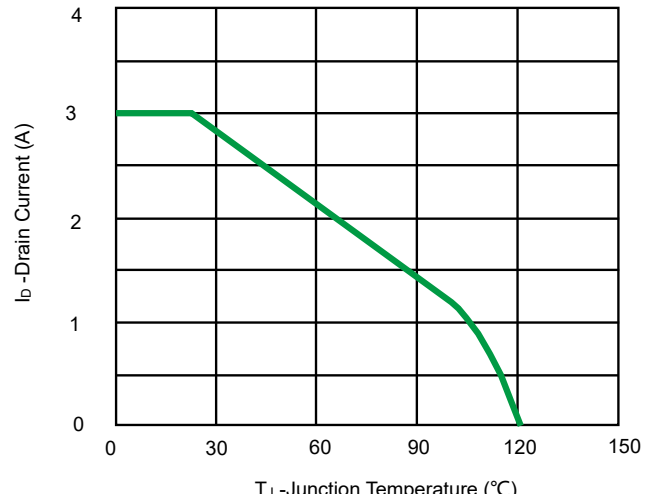

Figure 2. Switching Waveforms



T_j - Junction Temperature (°C)
Fig 3. Power Dissipation



T_j - Junction Temperature (°C)
Fig 4. Drain Current

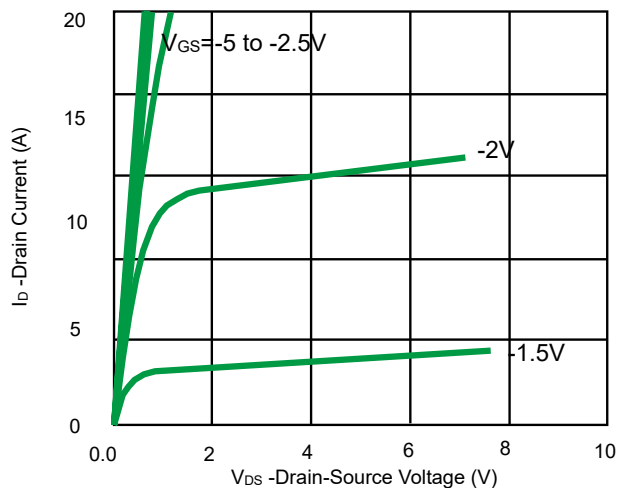

Fig 5. Output Characteristics

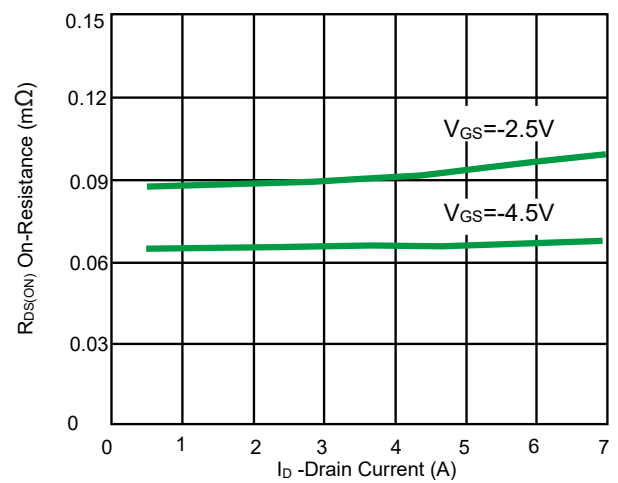

Fig 6. Drain-Source On-Resistance

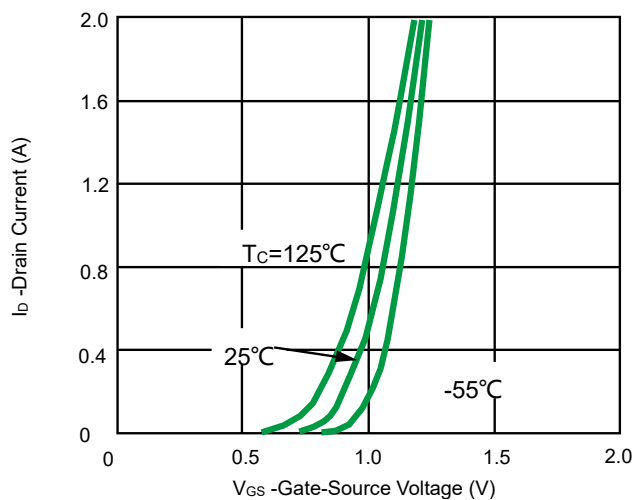

Fig 7. Transfer Characteristics

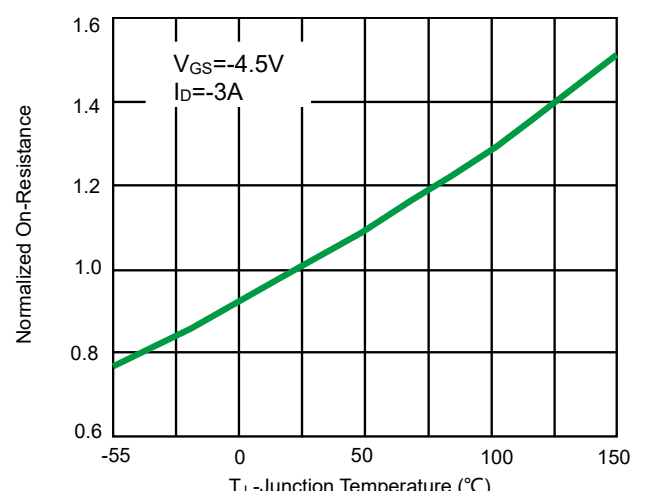

Fig 8. Drain-Source On-Resistance

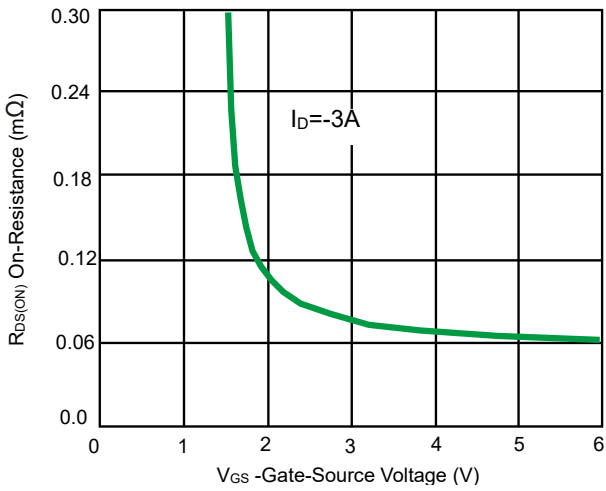

Fig 9. $R_{DS(ON)}$ vs. V_{GS}

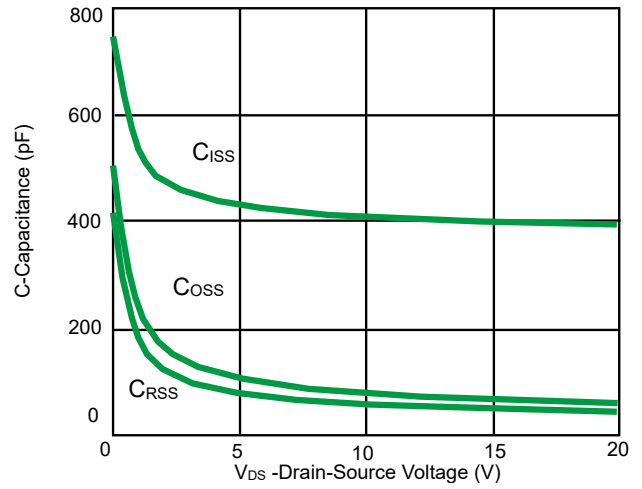

Fig 10. Capacitance vs. V_{DS}

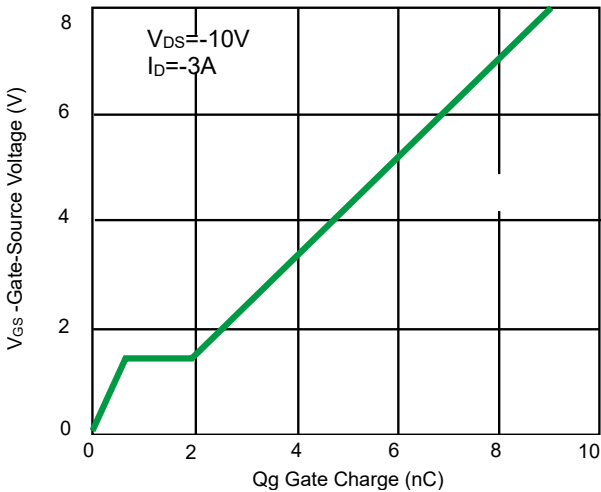

Fig 11. Gate Charge

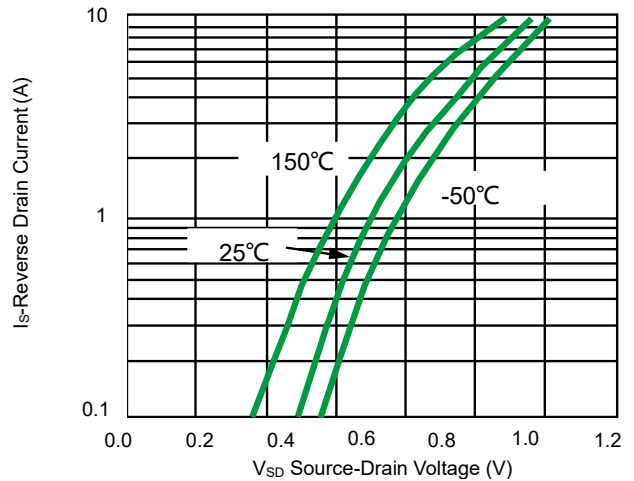

Fig 12. Source-Drain Diode Forward

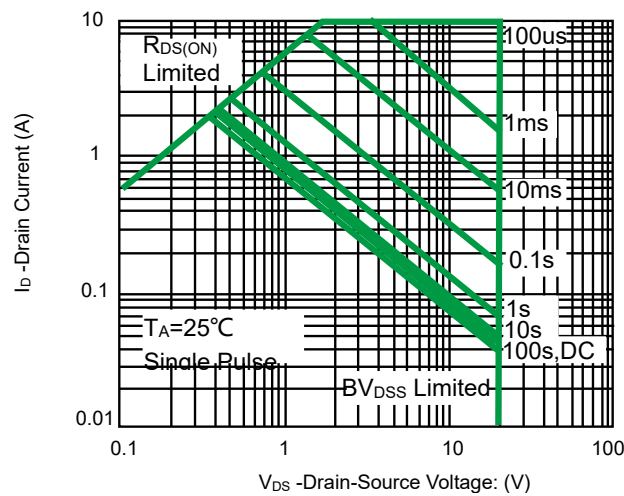

Figure 13. Safe Operation Area

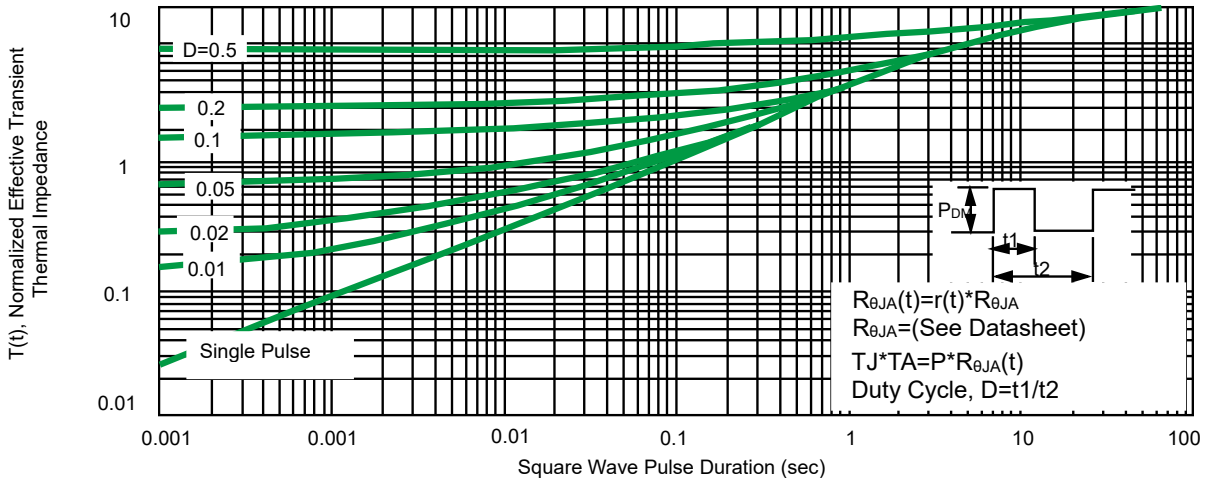
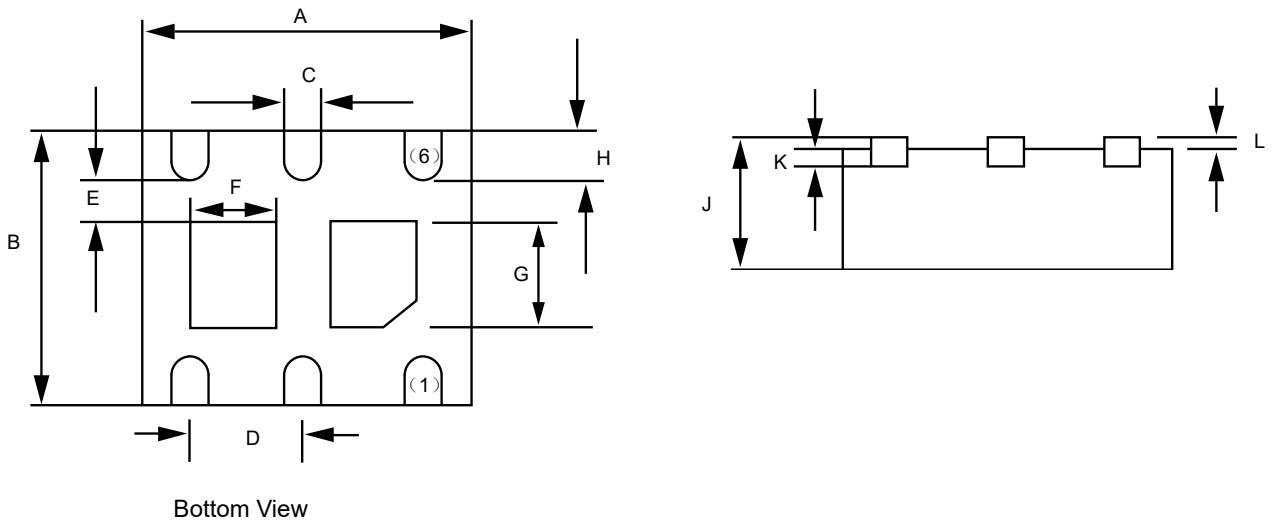
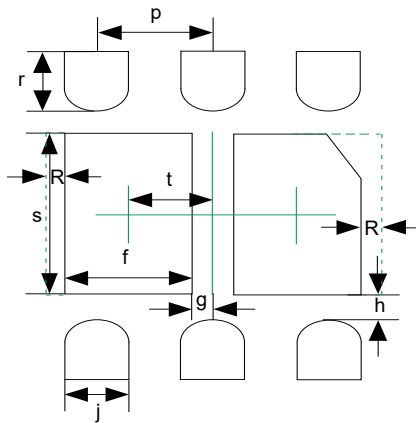

Fig 14. Normalized Maximum Transient Thermal Impedance

Product dimension (DFN2020-6L)



Dim	Millimeters		Inches	
	MIN	MAX	MIN	MAX
A	1.924	2.076	0.076	0.082
B	1.924	2.076	0.076	0.082
C	0.250	0.350	0.010	0.014
D	0.650 (typ.)		0.026 (typ.)	
E	0.200 MIN.		0.008 MIN.	
F	0.520	0.720	0.020	0.028
G	0.900	1.100	0.035	0.043
H	0.174	0.326	0.007	0.013
J	0.700	0.800	0.028	0.031
K	0.206 REF		0.206 REF	
L	0.203 REF		0.203 REF	



If there is enough place in PCB. It can be mounted with copper along the dotted line in order to optimize thermal design.

Dim	Millimeters	
	MIN	MAX
p	0.60	0.70
r	0.40	0.50
s	1.05	1.15
t	0.42	0.52
f	0.67	0.77
g	0.06	0.16
h	0.1	0.2
j	0.35	0.45
R	0.1	0.2

Ordering information

Device	Package	Shipping
PDPM6N20V3	DFN2020-6L	3000 / Tape & Reel

Load with information

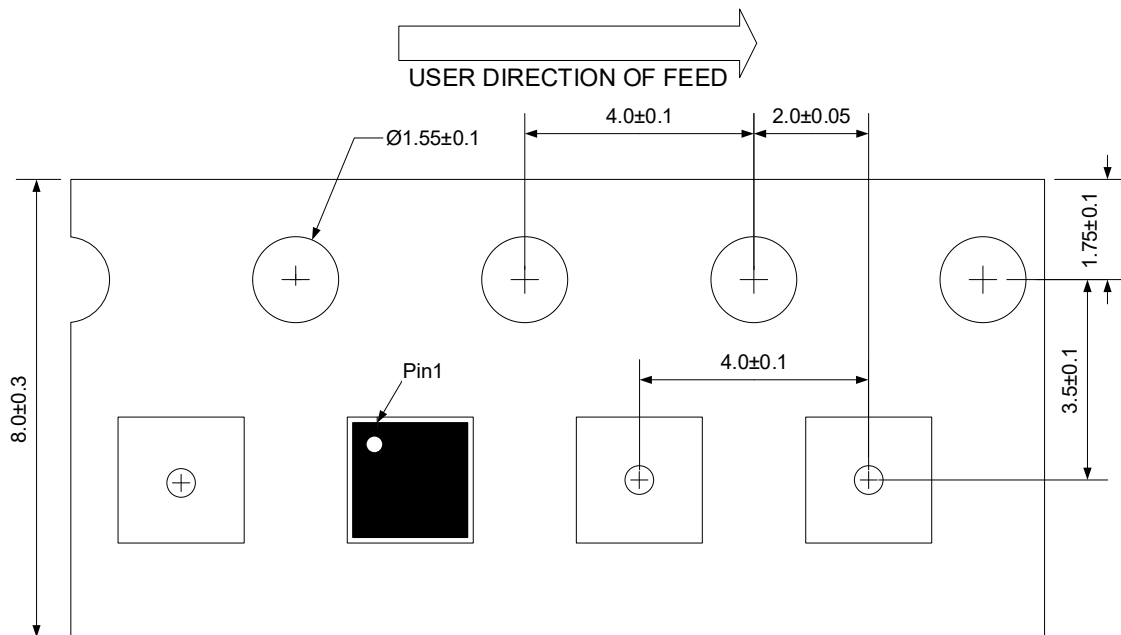

Unit:mm

IMPORTANT NOTICE

 and **Prisemi**[®] are registered trademarks of **Prisemi Electronics Co., Ltd (Prisemi)** ,Prisemi reserves the right to make changes without further notice to any products herein. Prisemi makes no warranty, representation or guarantee regarding the suitability of its products for any particular purpose, nor does Prisemi assume any liability arising out of the application or use of any product or circuit, and specifically disclaims any and all liability, including without limitation special, consequential or incidental damages. “Typical” parameters which may be provided in Prisemi data sheets and/or specifications can and do vary in different applications and actual performance may vary over time. All operating parameters, including “Typicals” must be validated for each customer application by customer’s technical experts. Prisemi does not convey any license under its patent rights nor the rights of others. The products listed in this document are designed to be used with ordinary electronic equipment or devices, Should you intend to use these products with equipment or devices which require an extremely high level of reliability and the malfunction of with would directly endanger human life (such as medical instruments, aerospace machinery, nuclear-reactor controllers, fuel controllers and other safety devices), please be sure to consult with our sales representative in advance.

Website: <http://www.prisemi.com>

For additional information, please contact your local Sales Representative.

©Copyright 2009, Prisemi Electronics

 **Prisemi**[®] is a registered trademark of Prisemi Electronics.

All rights are reserved.